

DARAY[®]
Medical



BH200

LED Patient Light

Operating & Installation Manual

Table of Contents

1. Introduction.....	3
1.1 Supported Lights	4
2. Technical Specifications	5
2.1 Pre-Installation Responsibilities and component packing list ...	6
2.2 Pre-Start Checks	6
3. Operation	7
3.1 Range of Motion	7
3.2 Powering On & Variable Intensity	8
4. Installation	9
4.1 Wall mounted version (BH200LW)	9
4.1.1 Considerations.....	9
4.1.2 Placement and Installation	10
4.2 Rail mounted version (BH200LR).....	12
5. Maintenance	13
5.1 Maintenance schedule.....	13
5.2 Safety Precautions	13
5.3 Product cleaning & care guidelines	14
5.4 Adjustments	15
5.4.2 Detaching Parts	15
6. Troubleshooting Guide & Spare Parts	16
7. Warranty Information	18
7.1 Returns Policy	18
7.2 Warranty Details	19

1. Introduction

DARAY's BH200 LED is a state-of-the-art, low-cost patient light. The light uses the latest next-gen LED technology with no heat in the light beam.

The BH200 LED head swivels on a flexible arm to allow accurate and stable positioning of the light patch. Its head and handles are coated with DARAY's BioProtect™, an antimicrobial protection against bacteria such as MRSA. Wall or rail mountings are available.

The light comprises 4 parts: light head, flexible arm, power-supply unit, and mounting. The flexible arm allows the light patch to be placed accurately and stably where it is needed. The arm is covered with a PVC sleeve to prevent contamination and to allow easy cleaning.

The plug-in power-supply module contains an electronic transformer to provide a low voltage to power the light from the electrical mains.

The wall-mounting bracket provides a simple method of fixing the light to the wall, allowing the base of the arm to swivel in front of the wall; a screw prevents the arm from accidentally being pulled out of the bracket.

The rail-mount version features a clamp to fasten the light to a medical equipment rail which is optionally supplied in 1m lengths. The clamp can also be used to mount the light to a bed or trolley rail.

All versions are delivered in special-to-type packaging which identifies on the ends of the box the model type and serial number of the light within.

This user & installation guide contains all the information you need for installation, operation and maintenance.

Restrictions and Liabilities

Information in this document is subject to change and does not represent a commitment by DARAY. Changes made to the information in this document will be incorporated in new editions of the publication. No responsibility is assumed by DARAY for the use or reliability of software or equipment that is not supplied by DARAY.

For further information on our product range and find out more about our Company please visit www.daray.co.uk or call 0333 321 0971.

This product was designed & manufactured in Great Britain by:

**Daray Ltd.
Edison House
Robian Way
Swadlincote
Derbyshire
DE11 9DH**

1.1 Supported Lights

The Following Models are supported in this Manual	
BH200LW	BH200 LED Wall Mounted Light
BH200LR	BH200 LED Rail Mounted Light

2. Technical Specifications

Light Source	LED
Light Intensity (Lux) @ 0.5m	5,800 Lux \pm 5%
Light Intensity Adjustment Range	10% - 100%
Colour Temperature (Kelvin)	4,300K \pm 500
Colour Rendering Index (CRI)	95
Colour Rendering (R9)	88
Light Field Diameter (D50)	@ 0.5m: 280mm
Light Field Diameter (D10)	@ 0.5m: 640mm
Number of LED's	3
Power Consumption	12W 0.1A
Average Working Life	>50,000 Hours
Input Voltage	100 - 240V AC 50/60 Hz
Output Voltage	12V DC 1A
Temperature Rise on Patient/User	\leq 2 °C
Warranty Period	5 Years
IP Rating	54
NHS E-Class Code	FBU, FKR
Commodity Code	9018 908400
GMDN Code	12276

2.1 Pre-Installation Responsibilities and component packing list

This document is a guide to the steps that need to be performed to correctly install the BH200 Patient light. However, the work required to be performed is the responsibility of the owner or designated contractor/s.

All fixings between DARAY lights and the building super-structure must be approved by either the chief project engineer or an appropriate and competent structural assessor.

The components supplied by DARAY for fitting / installation should be the following items in the specified quantities.

BH200LR	Qty.	BH200LW	Qty.
Plug top transformer	1	Plug top transformer	1
Rail Clamp	1	Wall bracket + fixings	1
Thumb Screw for Rail Clamp	1	Thumb Screw for Wall Mount	
Light head and flexible arm	1	Light head and flexible arm	1
Microfibre cloth	1	Microfibre cloth	1
User Manual	1	User Manual	1

2.2 Pre-Start Checks



Please check that the power cable is without visible damage, harsh folds, knots or cuts in the rubberised coating.



When applicable, please check that the cable is fully inserted into the power socket, before switching the power on.



Please check that the head and all parts of the base are without visible damage.

3. Operation

3.1 Range of Motion

This is an image depicting the range of motion on the BH200 light (all versions)

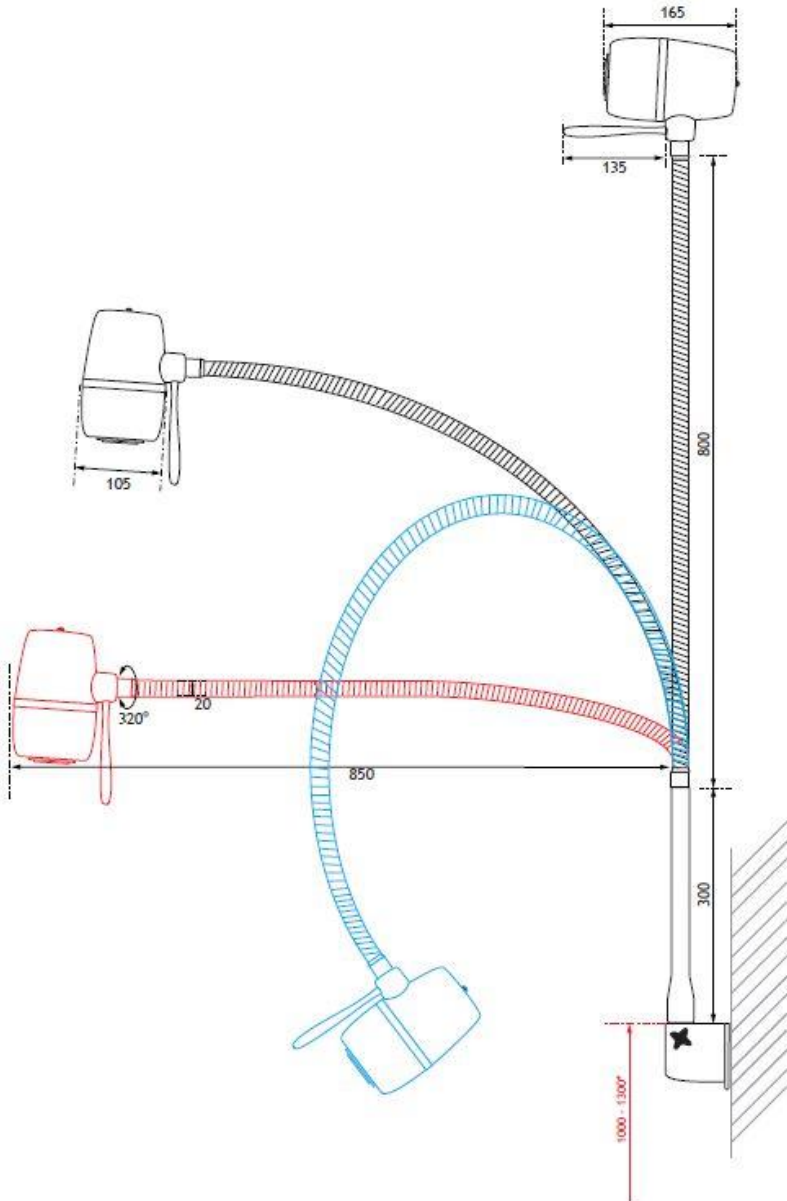

3.2 Powering On & Variable Intensity

The BH200 uses a single button on the back of the head to power the light on and off, and to adjust the brightness (intensity).

- Press once to power ON.
- Press and hold to adjust the intensity. It takes approximately 4 seconds to switch between the highest and lowest settings. Release the button when at a comfortable setting for the user.
- Press once to power OFF.

Please Note: The variable intensity control has a memory function; whereby, if the light is turned off at a dimmed level, it will remember that level the next time it is turned on.



4. Installation

4.1 Wall mounted version (BH200LW)



The wall bracket needs to be true on the vertical plane.



PIVOTW2 Wall bracket

4.1.1 Considerations

Wall Construction	<p>Before fixing it is important to consider the strength of the wall and the depth of the fixings used.</p> <p>Use of a building engineer or structural drawings may be required to decide on suitability.</p>
Examinations to be undertaken	<p>We recommend the bracket be installed approximately 850-1100mm from the floor to the underside of the bracket - dependent on couch height.</p> <p>It may be necessary to adjust this height, if there are specific medical procedures the light will be used for. If in doubt consult the end user or DARAY. When installing the bracket take consideration of where you want the light head to sit when in its lowest position.</p>
Locations of nearest mains sockets	<p>The BH200 wall mounted light uses a plug top transformer with a DC jack connection. Only the supplied certified power adapter should be used with the light.</p> <p>The length of this cable is approximately 1.5m so the wall mounted light should be within 1.2m of a mains power point</p>

4.1.2 Placement and Installation

- Remove the light from its packaging.
- Mark on the wall the selected location for the wall-mounting bracket, bearing in mind the final position of the light head required to project its light-patch where it will be needed.

We recommend 850-1100mm from the floor to the underside of the bracket - dependent on couch height. Ideally, the underside of the bracket should be 150-200mm above the couch.

- Taking note of the considerations in section 3.4.1, mount the PIVOTW2 wall bracket directly to the wall. Use a spirit level to ensure the bracket is on a true vertical plane.
- Once the bracket is installed, turn the thumbscrew anti-clockwise to allow a clear path through the hole, and then slide the light spigot directly into the hole in the bracket. Make sure the light is fully pushed in.
- Tighten the thumbscrew to secure the light in position.

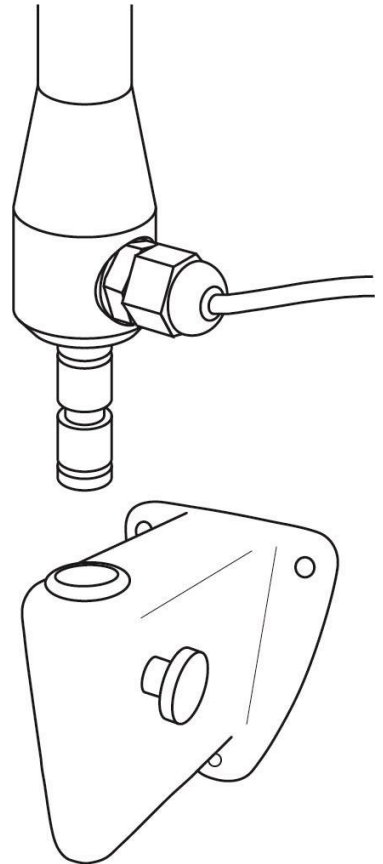

The power supply for the BH200 is a plug top transformer with a DC jack connection, these can be inserted into any standard UK wall socket.



Please note, under no circumstances should this product be connected directly to the Mains electrical supply, this product requires a Low Voltage Connection only and must only be used with a Daray Certified Power Adapter.

The light can now be tested by connecting the DC jacks and applying power. Press the switch on the head to power your light on. *See page 8*

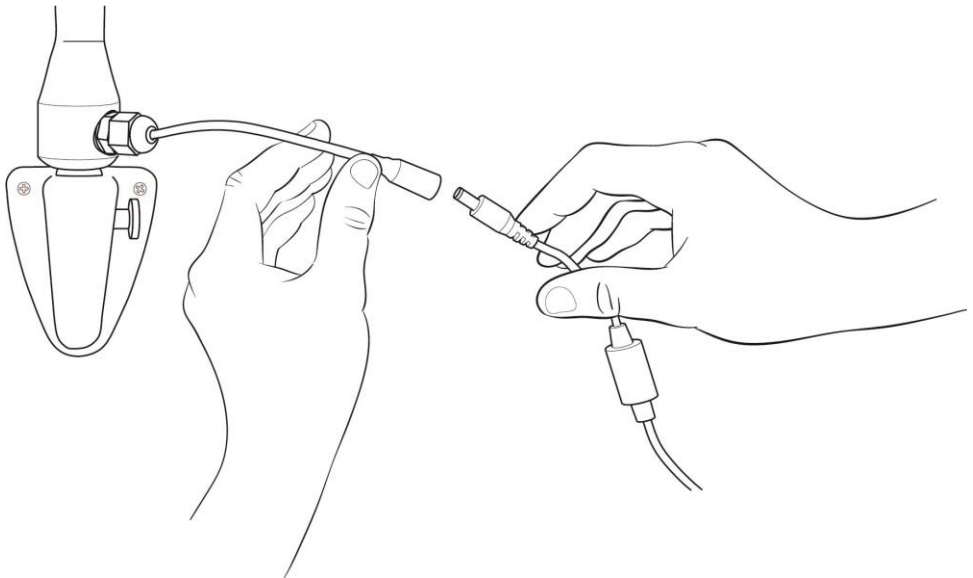

Check arm and head for smooth and correct movement. Your new DARAY light is now ready for use.

To gain full support of our warranty please fill in our warranty web form or contact **DARAY** by phone or email.



We also provide service plans to help you maintain your light. Contact **DARAY** on **0800 878 9864** for more details.

4.2 Rail mounted version (BH200LR)

- Remove the light from its packaging.
- *If you have also purchased our XRAIL accessory*, hold the rail against the selected location on the wall, bearing in mind the final position and range of travel of the light-head required to project its light patch where it will be needed.
- Ensuring the rail is horizontal; mark the positions for the 2 screw holes.
- Fix the rail to the wall, using appropriate plugs as necessary and the 2 screws provided.

NOTE: Slide the screw-head cap retainers the correct way up onto the screws before fitting the screws!

- Fit the screw-head caps.
- Ensure the rail end caps are properly fitted.
- Slacken sufficiently the light clamp to allow the clamp to pass over the rail and fit the light to the rail.
- The light can be moved along the rail by slackening the clamp slightly and not sufficiently to allow the light to become detached from the rail.

5. Maintenance

The proposed maintenance is only a suggestion. Depending on the use of the product and the operating environment, this may need to be revised more often.

DO NOT ATTEMPT ANY FIXES BEFORE CONSULTING DARAY.

If you cannot resolve a problem then please contact our helpline on **0800 878 9864** or email support@daray.co.uk

5.1 Maintenance schedule

Weekly checks should include:-	Range of movement testing, it should be light and easy to move throughout the range
	No visible signs of excessive wear.
Six monthly checks to include:-	Check all electrical connections are sound and that there is no visible cable wear.
	All fixings to be checked and be of sound construction.

5.2 Safety Precautions

- For all cleaning work, power off the equipment and where possible unplug the mains socket, only minimal cleaning fluids should be used.
- Please do not look directly into the light source when illuminated.
- If the equipment is dented or scratched this should not impact the usability of our lights however we advise that if the BioProtect® coating is damaged and the metal casing underneath is visible, please do not attempt to 'paint' over it as this will impact upon the effectiveness of the coating, simply use an alcohol based cleaning spray when cleaning and pay special attention to the cut.



If there is damage to the power cable or if exposed wire is visible
DO NOT USE

5.3 Product cleaning & care guidelines

The BH200 Range features BioProtect® antimicrobial coating on all painted surfaces and has a fully-enclosed head with an Ingress Protection (IP) rating of 54.

These guidelines are provided to help you maintain your equipment properly and prevent any damage. Use of incompatible cleaning chemicals can adversely affect the finish and physically damage the metal and plastic parts of the DARAY product, invalidating its warranty.

Please ensure these instructions are passed to the persons responsible for cleaning and they are followed before each use.

Manufacturers recommended cleaning method:

1. Turn off the power to the light, and where possible, unplug the mains socket.
2. Remove noticeable contamination. Pay special attention to the light head and handle.
3. Ensure the equipment is surface-cleaned and disinfected using an appropriate, non-abrasive cleaning agent (see recommended list below).
4. Dry all surfaces thoroughly with a clean cloth and check for damaged surfaces, discolouration and/or contamination.

NOTE: Some DARAY products feature our BioProtect® antimicrobial coating on painted finishes. This is designed to assist with infection control and is not a replacement for cleaning.

CAUTION: Our products are NOT waterproof. The equipment and accessories (included chargers and battery packs) MUST NOT at any point be saturated, to prevent water ingress. Use a damp cloth or saturated wipe if necessary. All electrical safety guidelines should be followed.

Any damage caused as a result of not following these guidelines will void any product warranty.

Below is a partial list of recommended surface agents:

- 
- Cavicide™ products
 - Isopropyl alcohol-based cleaners (<40% alcohol)
 - Ethyl alcohol-based cleaners (<40% alcohol)
 - Lysol® disinfectant
 - Other non-bleach and non-abrasive disinfectants or cleaners

DO NOT USE agents containing the following:

- 
- Organic, mineral and oxidizing acids (min. pH value 8.5)
 - Bases (max. acceptable pH value 8.5)
 - Oxidation agents (e.g. Hydrogen Peroxide)
 - Halogens (chlorine, iodine, bromide)
 - Aromatic/halogenized hydrocarbons
 - Bleach-based cleaners (e.g. Clorox™, Sterilox™)
 - Abrasive cleaners (e.g. Comet Cleaner™)
 - Acetone-based cleaners (e.g. nail polish remover, Goo-off™)
 - MEK (Methyl Ethyl Ketone)

If you are unsure whether you are using the correct cleaning fluids on your DARAY equipment, please feel free to get in touch with us for advice.

5.4 Adjustments

The head of the BH200 light has a total turning capability of 320 degrees, attempting to push further may cause damage to the movement and internal wiring of the light.

5.4.2 Detaching Parts

De-construction of the lights should be done following a reverse order of the instructions in section 4.





The BH200 is a completely enclosed light and arm it should not be opened and is not serviceable outside of a DARAY Authorised service centre.

For any issues requiring service work on the BH200 please contact DARAY, as unauthorised work will **invalidate the warranty**.

6. Troubleshooting Guide & Spare Parts

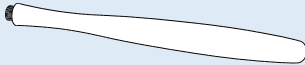
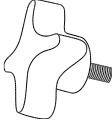
Problem	Possible Cause	Corrective Actions
No light output	Power Supply	Wall Version - Check the plug top adapter is plugged in and switched on at the power socket.
	On/Off/Intensity Button	Press the button on the back of the light to check if the light will power on (if dimmed refer to poor light output actions).
	Fuses	Visually check fuses then check continuity with meter
	Cables	Check the visible wiring and make sure the DC connectors between the light and the extension cable are fully connected
Poor Light output	Power Button	Please check the variable intensity is not just set to its minimum. To do this hold in the power button on the back of the head. This is the control used to adjust the intensity. If the light reduces more, simply remove your hand and then depress the button again
	Voltage in	Verify that the correct mains voltage and correct transformer is being used
	Voltage out	Verify correct secondary voltage
Arm drift sideways	Wall mount	On installation the arm has most likely not been vertically aligned and levelled. Please contact the original fitter or a qualified electrician

Picture	Description	Order Code
	Light-head handle	CS6142
	Wall bracket thumb screw	D16247
	Plug-top transformer	DRK4148

For any SPARE PARTS or TECHNICAL ISSUES phone DARAY'S Service Delivery Team on:

+44 (0) 800 878 9864

Opening times 9am-5pm Monday to Thursday (excluding bank holidays)
9am-2:30pm on Friday

Or email:

support@daray.co.uk

**IF THE LIGHT WAS ORIGINALLY PURCHASED THROUGH A DISTRIBUTOR CONTACT THEM IN
THE FIRST INSTANCE FOR A RESOLUTION**

Please contact DARAY for help with any problems that the distributor cannot solve.



7. Warranty Information

7.1 Returns Policy

IMPORTANT!
 Please fill out your warranty registration online at
www.daray.co.uk/warranty or contact Daray by phone (0800 878 9864)
 or email support@darav.co.uk

DARAY's standard warranty is 12 months. However, this period may be extended to 5 years* free of charge by completing and submitting the warranty registration. For the specific warranty period for this product, please refer to the warranty symbol in the upper right of this page.

Year 1:	Warranty includes parts and labour (Return to Base)	*UK only
Year 2-5:	Parts only	

We want you to be completely satisfied with your purchase. If you need to return goods purchased from DARAY Ltd, please read the following information carefully. The DARAY Ltd returns policy provides guidance on when you can return goods we have supplied, and what you can expect from us once you do. To see our detailed returns policy and procedure visit www.daray.co.uk/returns

TYPE OF RETURN	REMEDY
DAMAGED GOODS Goods which are physically damaged on delivery	We must be notified within 24 hours of receipt.
Dead On Arrival (DOA) Goods which do not work	Goods which do not work on arrival or develop a fault within 28 days, we will advance replace the item.
GOODS DEVELOPING A FAULT Goods which have developed a fault within the warranty period.	If the fault develops after 28 days, but within the warranty period, we will initiate the returns procedure.
NON WARRANTY Goods which have developed a fault outside the warranty period.	If a fault develops outside the warranty period, we will initiate the returns procedure charges may be applicable.
OTHER Any situation which is not covered by any of the above.	We will always try to help, but we cannot normally offer a refund.

For additional clarification, please refer to our terms and conditions at www.daray.co.uk/terms. In a small number of cases, we may determine that a replacement would not work any better than the original product we supplied. In such cases we will only offer a refund rather than a replacement for qualifying returns. Replacement bulbs and spare parts ordered on our website or from supplied part codes are not eligible for credit. We will accept returns and exchange for the correct item. If your purchase an item incorrectly you can return it within 14 days and it can be exchanged for another product of equal or higher value, excluding transportation charges incurred. Goods and packaging must be returned in their original condition. Under no circumstances will goods be accepted for return if they are damaged, have been subjected to improper handling or abuse or have been used. If you send us goods that do not qualify for return, you will invalidate your claim to any refund, and you will be obliged to compensate DARAY Ltd for the cost of return postage and any other reasonable costs incurred processing the goods. Your statutory rights are not affected.

7.2 Warranty Details

TERMS AND CONDITIONS OF WARRANTY

1. To qualify for this warranty you must register on www.daray.co.uk or return to Daray Ltd (Daray) the duly completed warranty-registration form accompanying the product.
2. Daray warrants this product (excluding lamp) against faulty material and workmanship during the period of the warranty. The period of warranty is the period stated on your warranty card and commences on the date of purchase of the product. In the event that the product is not in good working order Daray will provide, during the warranty period, a free repair service within the United Kingdom. The warranty is subject to proof of purchase being provided; therefore, you should retain your original receipt.
 - 2.1 The repair service consists of the provision of spare parts and/or replacement products (at Daray's discretion) which will be provided on an exchange basis and will either be new, equivalent to new or reconditioned. All replaced spare parts and products shall become the property of Daray.
 - 2.2 Daray's only obligation under this warranty is the provision of the service as set out above.
 - 2.3 All products are returned to Daray at the customer's cost and risk. Products to be returned should be adequately packed. For the address to send returns to please visit www.daray.co.uk
3. Daray's arrangements for providing service provided under this warranty may include the use of sub-contractors.
4. This warranty does not cover damage or defects in the Product caused by or resulting from:
 - Wilful neglect or negligence by anyone other than Daray;
 - Improper use, storage or handling of the product;
 - Use of non-Daray approved parts (such as replacement lamps) not compatible with the Product;
 - Fire, accident or disaster;
 - Use of non-Daray modifications other than in accordance with Daray's instructions;Attachment of fittings and accessories not approved by Daray;
Repairs, modifications carried out by service personnel not approved by Daray;
 - Damage caused by chemical corrosion from cleaning agents not approved by Daray.
 - Failure to use or install the product in accordance with the manufacturer's instructions.
5. Nothing in this warranty shall have the effect of restricting or excluding the liability of Daray in respect of:
 - a) Death and personal injury caused by the negligence of Daray, or for fraud;
 - b) Under the *Consumer Protection Act 1987* to a person who has suffered damage caused by a defective product or to a dependant or relative of such a person;
 - c) Direct damage to your property caused by the proven negligence of Daray.
6. This agreement does not give any rights other than those expressly set out above and in particular, Daray will not be responsible for any loss of income, profits or contracts or any direct or indirect consequential loss, damage caused to or suffered by the purchaser as a direct result of this agreement.
7. This warranty is offered (subject to these terms and conditions) in addition to, and does not affect your statutory rights.
8. Daray may disclose your details and other personal information to companies within the Daray group including any subsidiary company or sub-contractor of Daray for the purposes of performing our obligations hereunder.
9. You must not resell outside the UK any products supplied by Daray and covered by the *Export of Goods (Control) Order 1992* (or any law that replaces it) without obtaining all necessary licences. You also agree not to sell the product in the UK if you know or think that the person buying the product intends to export it without getting the necessary licences. You agree to impose similar conditions to these on anyone you sell the product to.
10. These conditions shall in all respect be governed and construed in accordance with English law and the exclusive jurisdiction of the English courts.

Product:

Serial No:

--

DARAY[®]
Medical

DARAY Ltd.
Edison House
Robian Way
Swadlincote
Derbyshire
United Kingdom
DE11 9DH

 +44 (0)800 878 9864

 +44 (0)333 321 0973

sales@daray.co.uk • www.daray.co.uk
